

**YOUR BENEFIT:**

- Maintenance-free operation
- Many customization options
- Universal monitoring options

CHEMICAL STANDARD PUMP **NML**

# CHEMICAL STANDARD PUMP NML

## Description / Application

The Type NML is a chemical standard pump PN16 according to ISO 2858 with magnetic coupling.

It is tailored to deviating dimensions from the characteristic curve and the requirements of the operators, so that an optimal efficiency is achieved.

The pump is equipped with a permanent magnet coupling, and the containment shell hermetically seals the conveying medium to the outside. Heat generated by eddy current losses is dissipated through an internal circulation flow.

The pump shaft is supported by SiC sleeve bearings, while the drive shaft is placed in permanently lubricated antifriction bearings. Wear rings are standard on the suction and pressure sides. Axial thrust compensation is achieved through relief bores, back vanes or other measures.

### Applications

- Oil & Gas
- Chemistry & Petrochemistry
- Offshore
- Ship technology & Marine
- Refueling equipment & Aviation
- Tank storage & Tank farms
- Renewable energy & Environmental engineering

Info NML



# CHEMICAL STANDARD PUMP NML

## Technical Data

### Design

Pump type	Volute casing pump
Stages	Single-Stage
Sealing	Magnetic coupling
Set-up	Horizontal
Self-priming	No
Bearings	Antifriction bearing, sleeve bearing***
Lubrication	Grease

### Material

Spheroidal graphite iron (EN-GJS), Cast steel (GP 240 GH), Austenitic cast steel (1.4408/1.4571), Duplex (1.4517), Ni-Based (2.4686)

### Technical Data

Q max*	500 m <sup>3</sup> /h [2200 gpm]
H max*	250 m [820 ft]
Operating pressure**	16/24/40 bar [232/348/580 psi]
Temperature**	200°C [390°F]
max. speed	3500 rpm

\*\* depending on size and speed

\*\* higher temperatures and pressures on request

\*\*\* product side

### Norm

ISO 2858 / ISO 15783

Explosion protection: Category 2 / Zone 1

# CHEMICAL STANDARD PUMP NML

## Sectional View

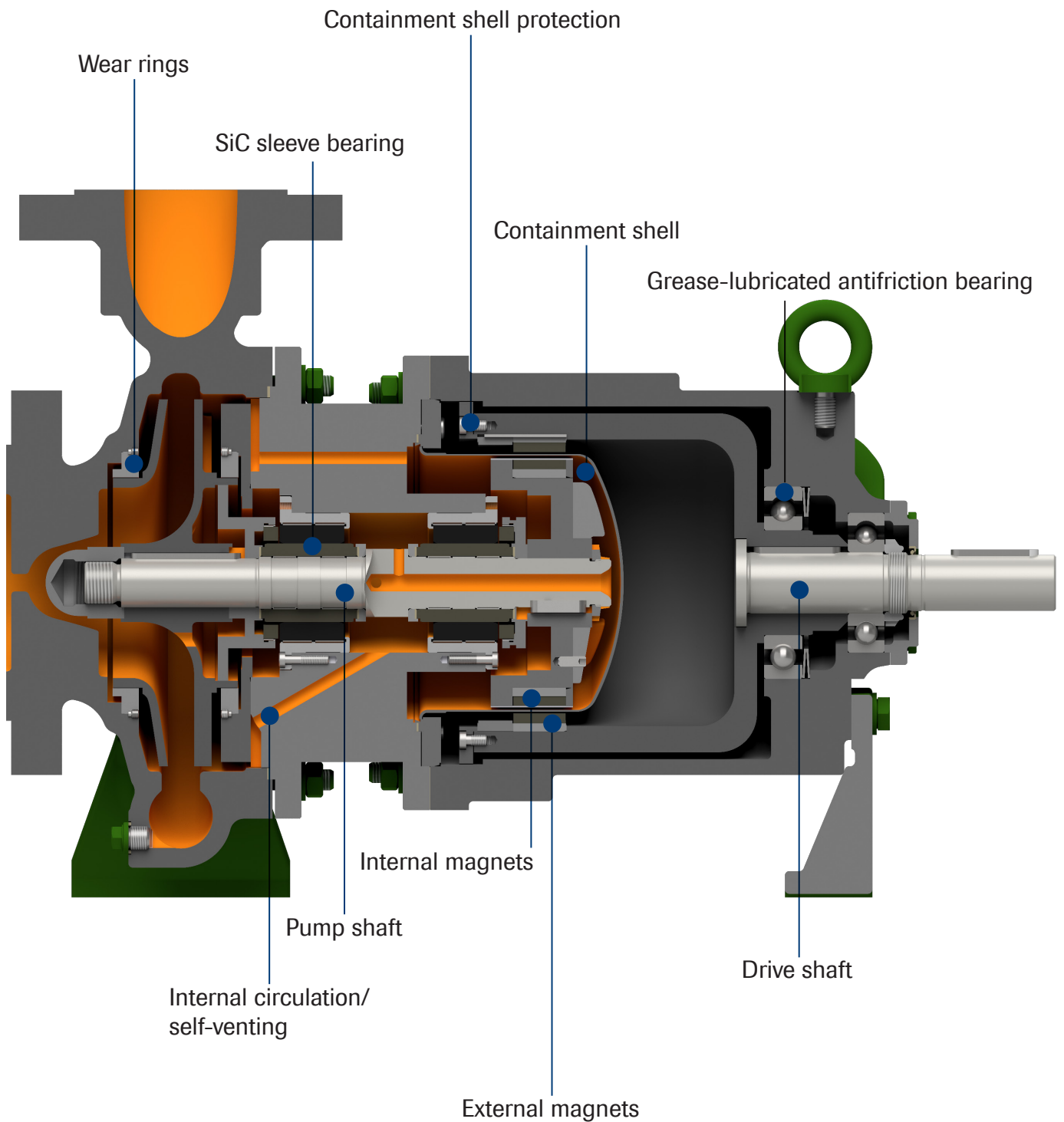

**Address**

Dickow Pumpen  
GmbH & Co. KG  
Siemensstrasse 22  
D-84478 Waldkraiburg

**Phone**

+49 (0)8638 602-0

**Internet**

info@dickow.de  
www.dickow.de

Homepage:

